



Hudson Boosters Football

Grades 5 & 6

Primary Running Plays

- Blast or Dive – Typically led by a blocking fullback, the running back takes a quick handoff from the quarterback and hits a hole between an offensive guard and a tackle.
- Counter – An intentional misdirection run. The quarterback fakes a lateral toss to one running back, then turns and hands off to the remaining runner in the backfield who runs in the opposite direction.
- Off-Tackle – Strong-side run which means the running back goes toward the end of the line where the tight end lines up. The ball carrier should take advantage of the hole supplied by the tackle and tight end.

Primary Running Plays

- Pitch - The quarterback tosses (or pitches) the ball underhand laterally to the other running back, who has begun to move to the outside.
- Sweep – The running back takes a handoff and runs parallel to the line of scrimmage, waiting for his blockers to lead the way around the end. The run is designed to attack the defensive end, outside linebacker, and cornerback on a specific side.
- Reverse - The running back takes a handoff and runs laterally behind the line of scrimmage like a Sweep. The ball carrier then meets up with a wide receiver or flanker running toward him and hands the ball to that player.
- Draw – Quarterback takes three step drop to show defense he is throwing, but then hands ball to running back who runs straight forward between the center and guard.

Receiver Route Tree

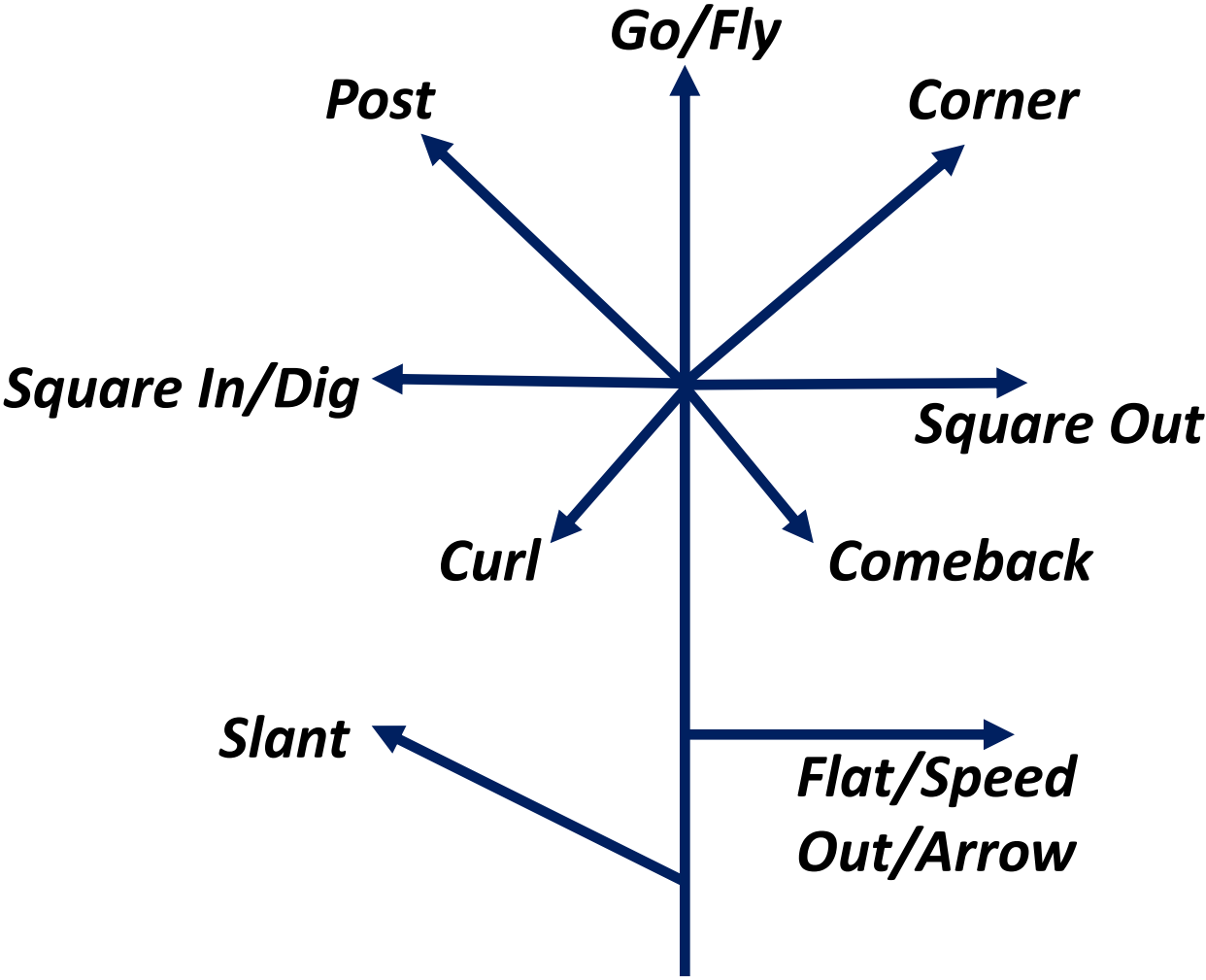
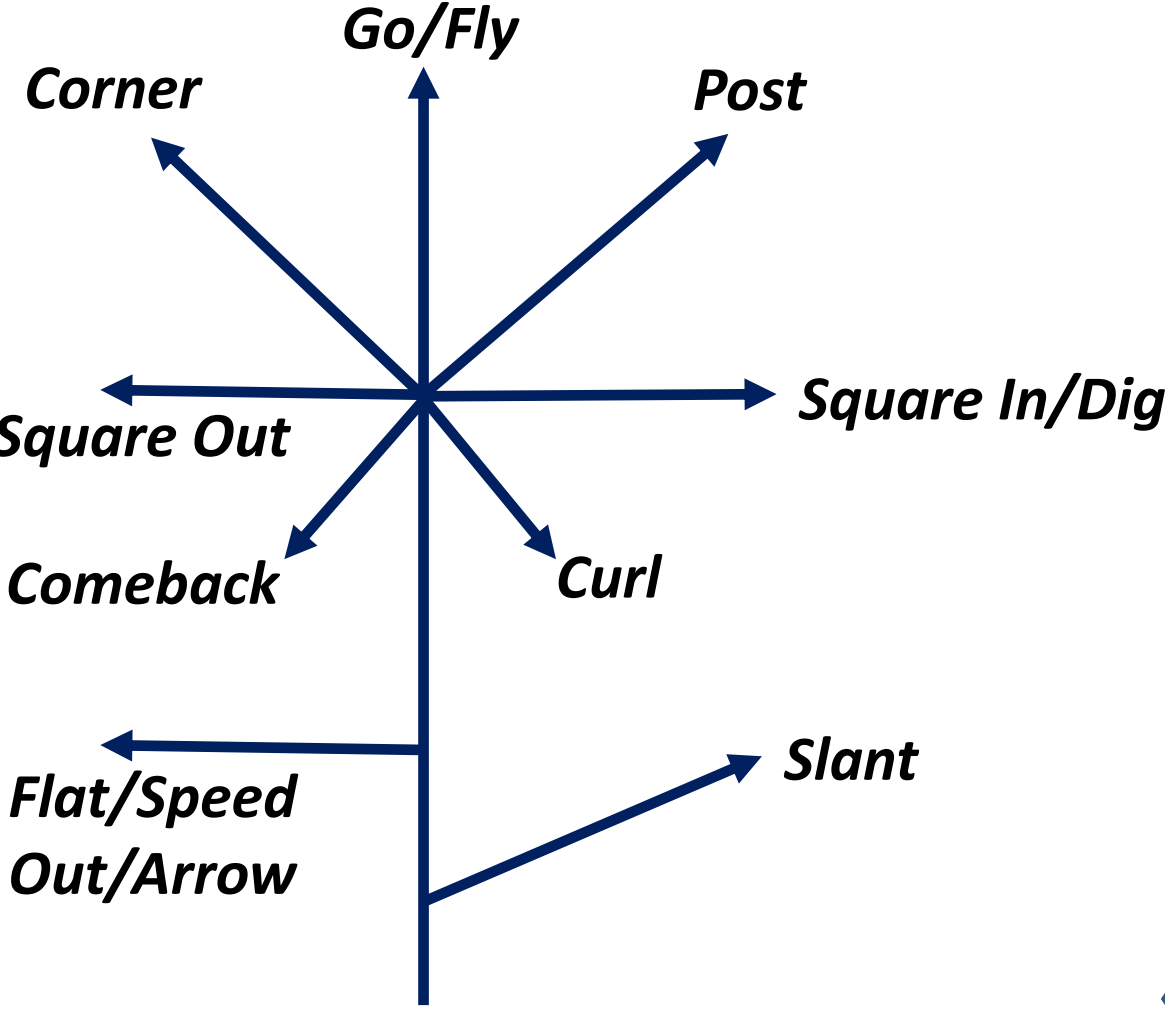

5th/6th Grade Position Designations

- (Q) Quarterback – Receives plays from coach, initiates action and handles the “snap.” Q either hands the ball to the running back or passes the ball to a receiver. The Q must be able to throw the ball with power and accuracy.
- (T) Running Back - Also known as a Tailback or Halfback. This player lines up either behind or beside the quarterback. T runs and catches and will throw a pass from time to time.
- (C) Center – Player focused on a quality “snap” of the ball to the Q.

5th/6th Grade Position Designations

- (RG & LG) Right Guard & Left Guard – Inner two members of the offensive line whose jobs are to block for and protect the quarterback and ball carriers.
- (RT & LT) Right Tackle & Left Tackle – Outer two members of the offensive line whose jobs are to block for and protect the quarterback and ball carriers.

5th/6th Grade Position Designations

- (X) Wide Receiver – X receivers are known as pass catchers, but will occasionally take a handoff. They start plays split out wide from the rest of the formation and typically on opposite side of the field as the Z receiver.
- (Z) Flanker - Z receivers are known as pass catchers, but will occasionally take a handoff. They start plays split out wide from the rest of the formation and typically on opposite side of the field as the X receiver.
- (Y) Tight End – Y is a hybrid between a receiver and an offensive lineman. Generally, Y is the receiver that lines up closest to the football. The Y runs routes like an X or a Y.
- (H) H-Back - The H-Back is a cross between the tight end and full back positions. The H runs routes like an X or a Y.



Playbook Overview

Pistol Offense

- Quarterback lines up 3-4 yards behind Center and takes shotgun snap
- Base offense is an “Offset I” formation
- All players must know the run play holes and the run call player numbering system (described on page 8)

“Offset I” Alignment

- Tight End (Y) and Flanker (Z) are on the right side of the Center (C)
- H-Back (H) and Wide Receiver (X) are on the left side of the (C)
- Running Back (T) will line up directly behind the Quarterback (Q)
- Q will be 3-4 yards behind C in shotgun formation
- C, Guards (G) and Tackles (T) block defenders in their zone

Core Rules

- Max line split is hand to hand
- Minimum line split is 1 foot between the feet of players
- No motion of any kind is allowed from any position
- Head-to-head blocking only (no cross-blocks, double teams, or crack-back blocks allowed)
- No quarterback sneaks or designed plays where the quarterback runs between tackles

I-Formation Play Call Basics

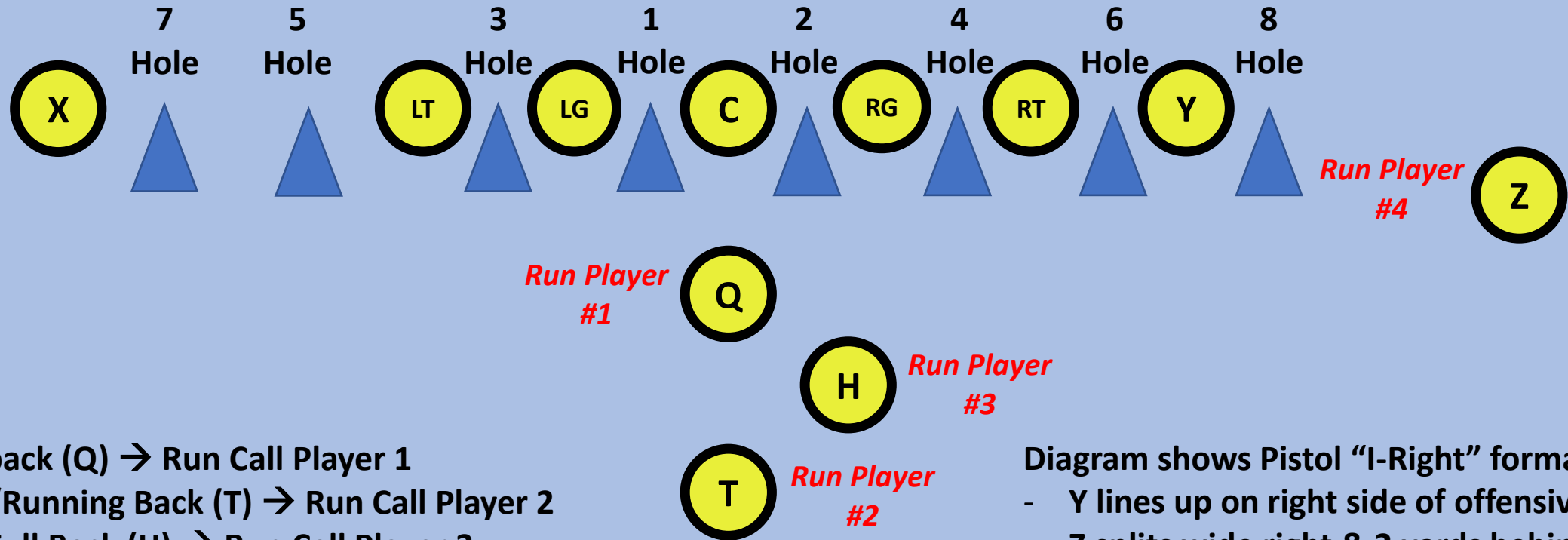

Quarterback (Q) → Run Call Player 1
 Tailback/Running Back (T) → Run Call Player 2
 H-Back/Full Back (H) → Run Call Player 3
 Flanker (Z) → Run Call Player 4
 Wide Receiver (X)
 Tight End (Y)

Diagram shows Pistol “I-Right” formation:

- Y lines up on right side of offensive line
- Z splits wide right & 2 yards behind line
- X splits wide left & directly on the line
- H is 1 yard behind & right of the Q
- T is 3 yards directly behind Q
- Q aligns 3-4 yards behind Center



RUNNING PLAYS

Pistol Offset I-Formation

I-Right 28 Sweep

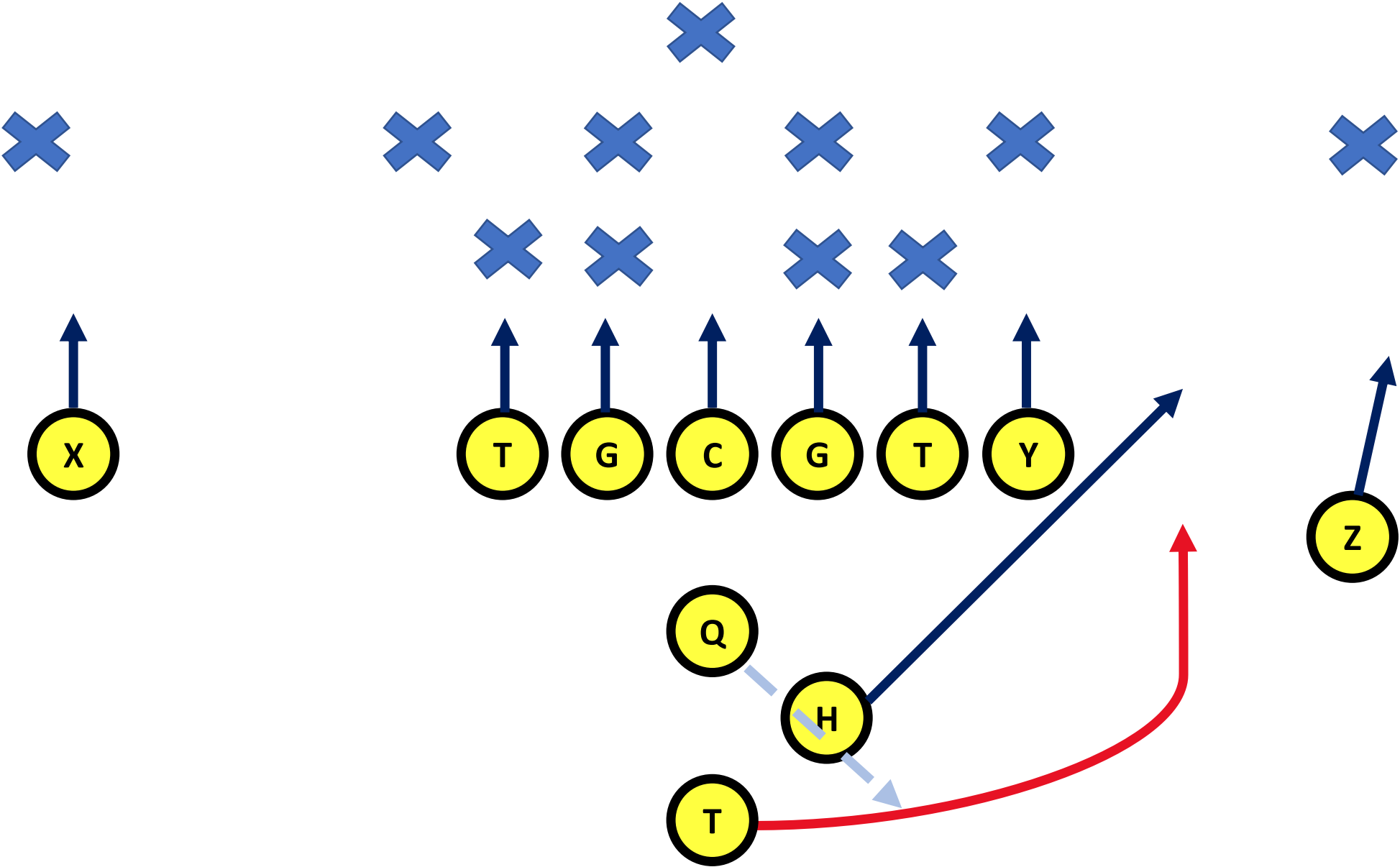

I-Left 27 Sweep

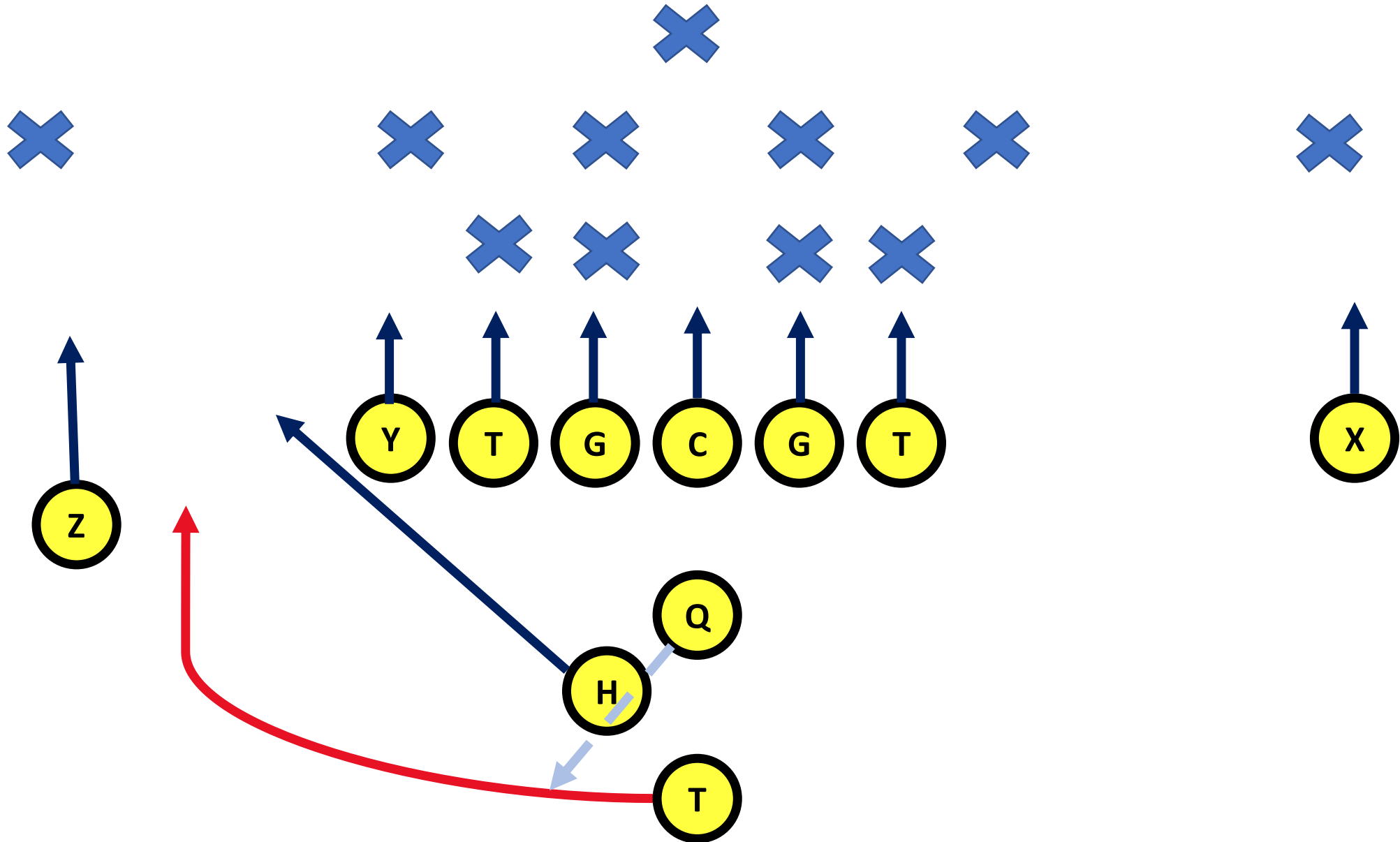

I-Right 24 Blast

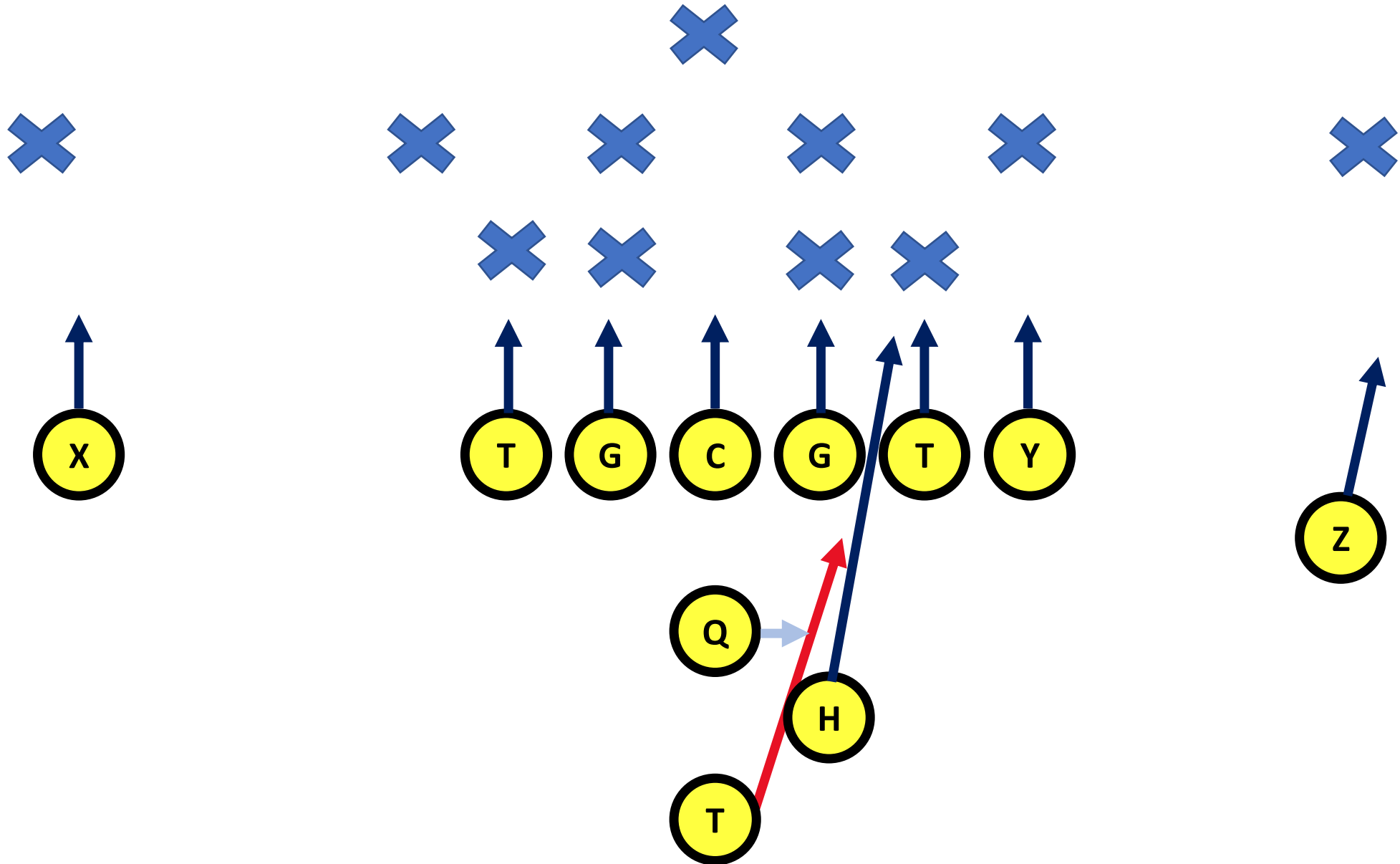

I-Left 23 Blast

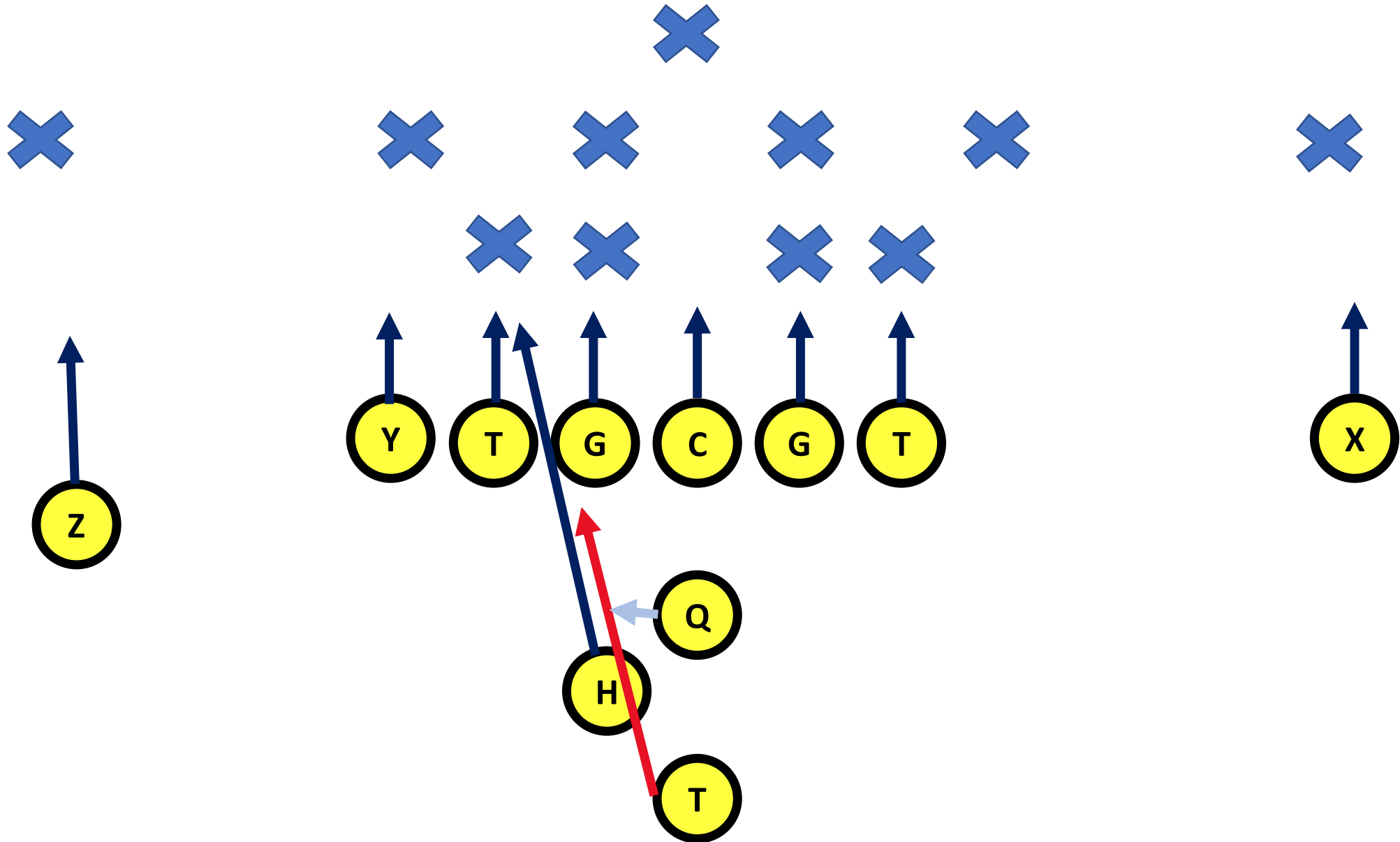

I-Right 32 Dive

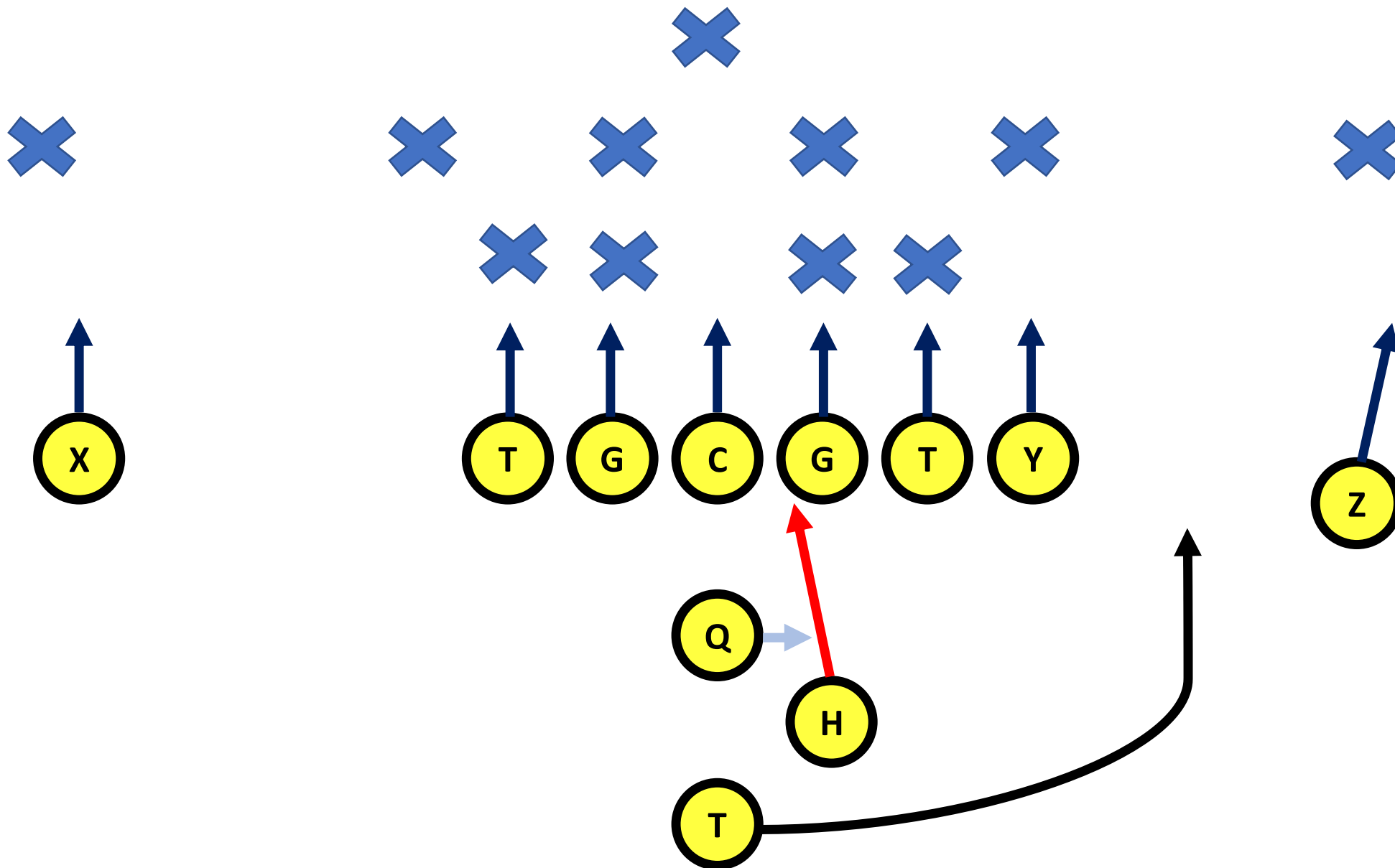

I-Right 32 Option

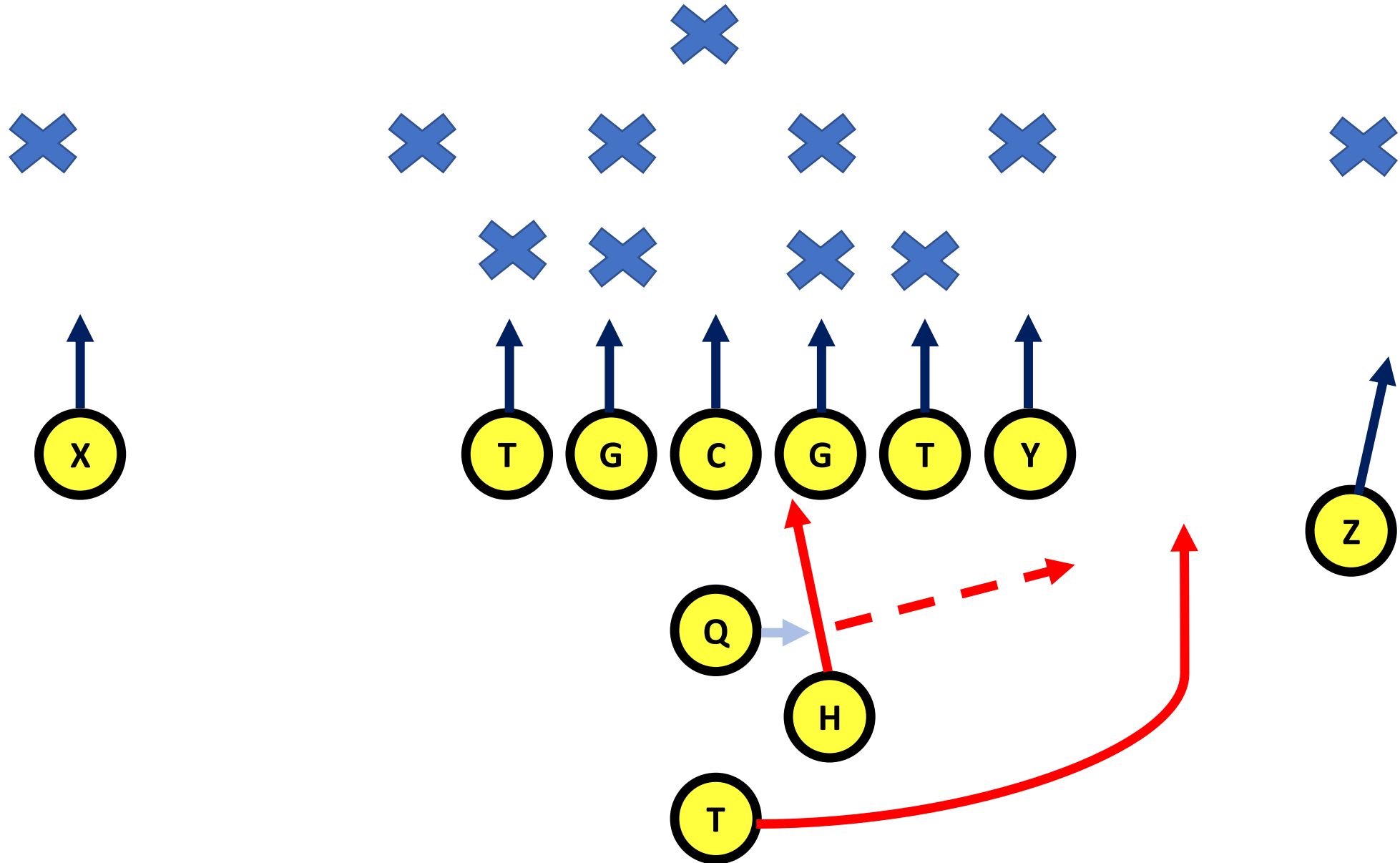

I-Right Speed Option

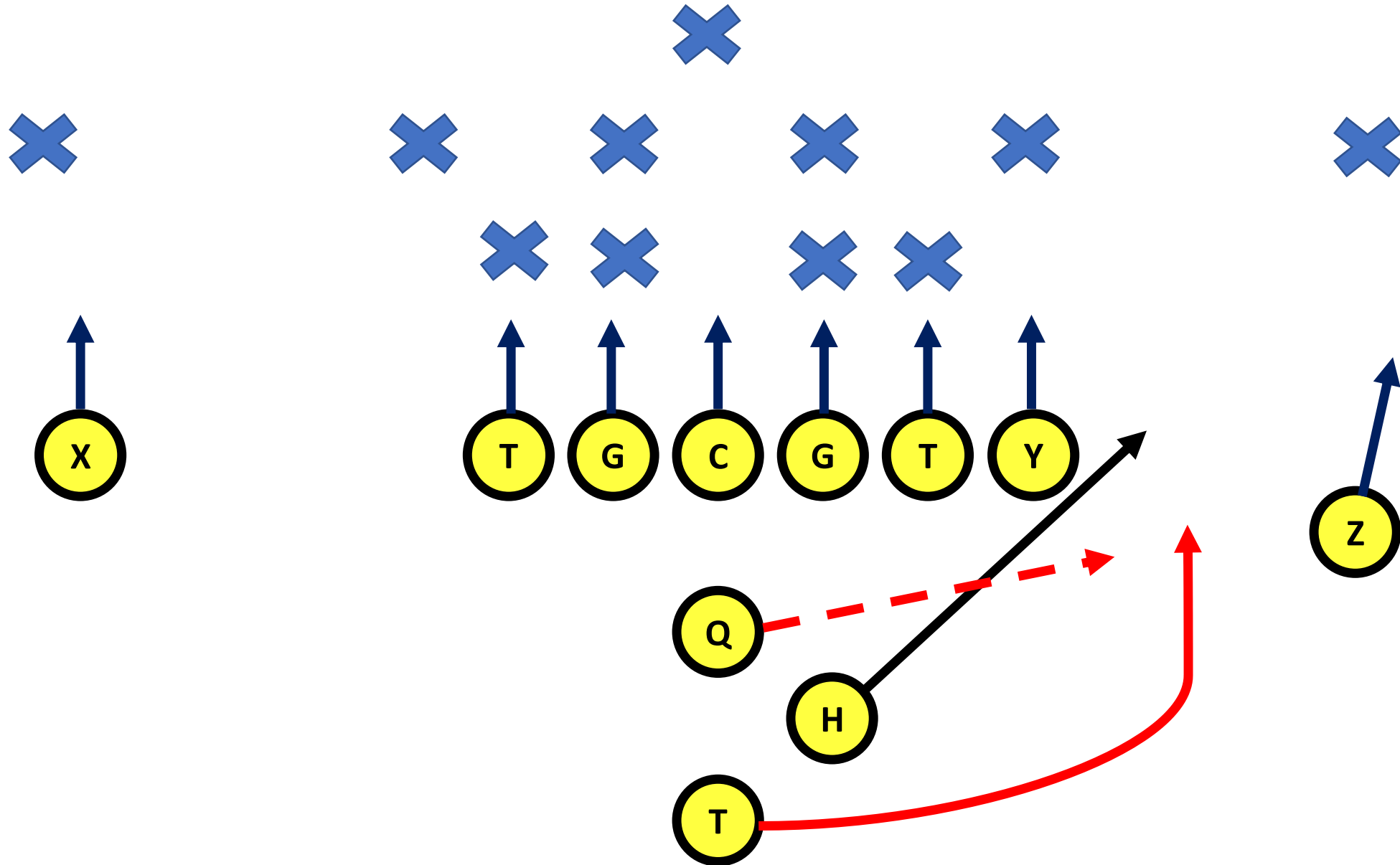

I-Right 37 Counter

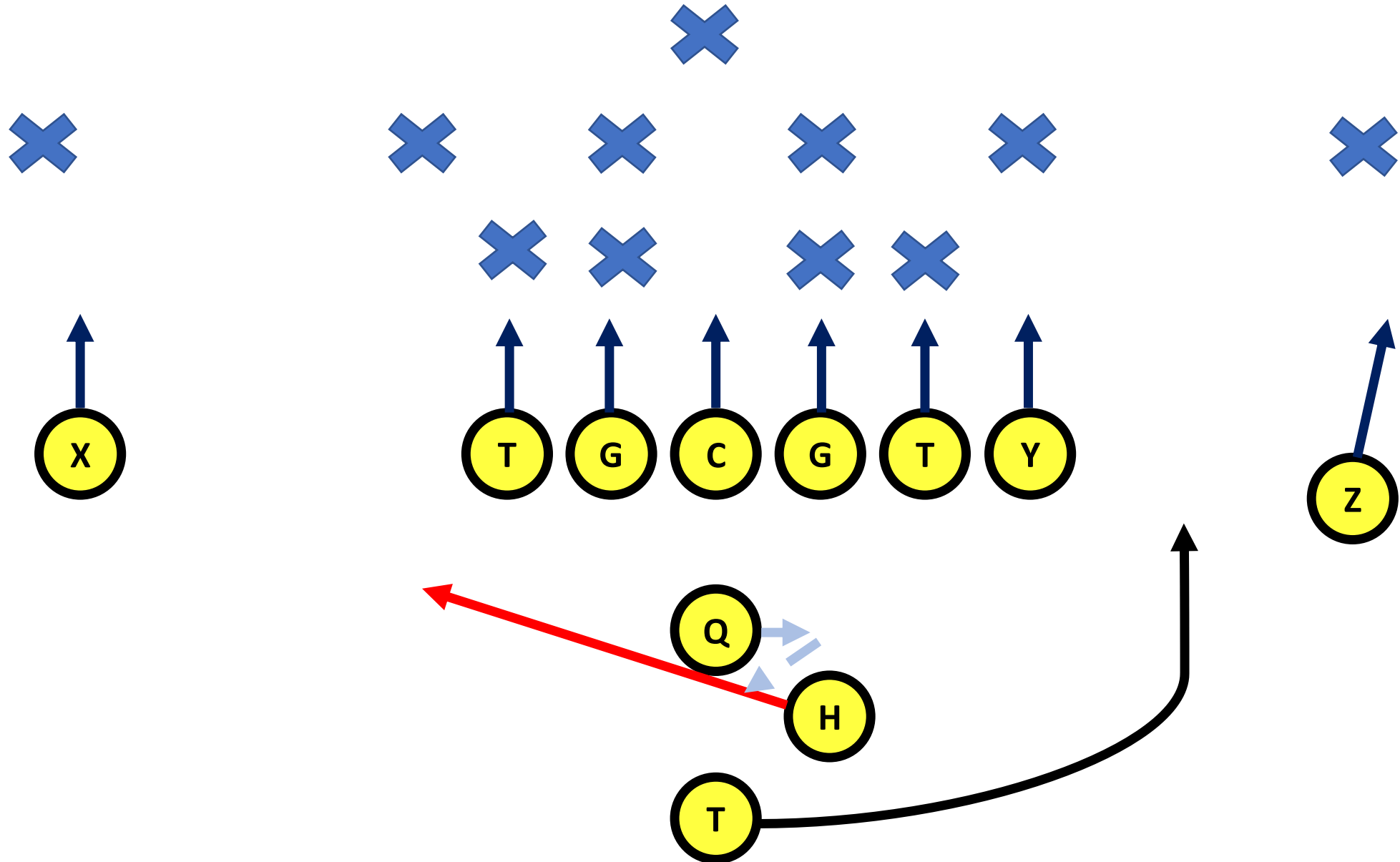

I-Right 24 Draw

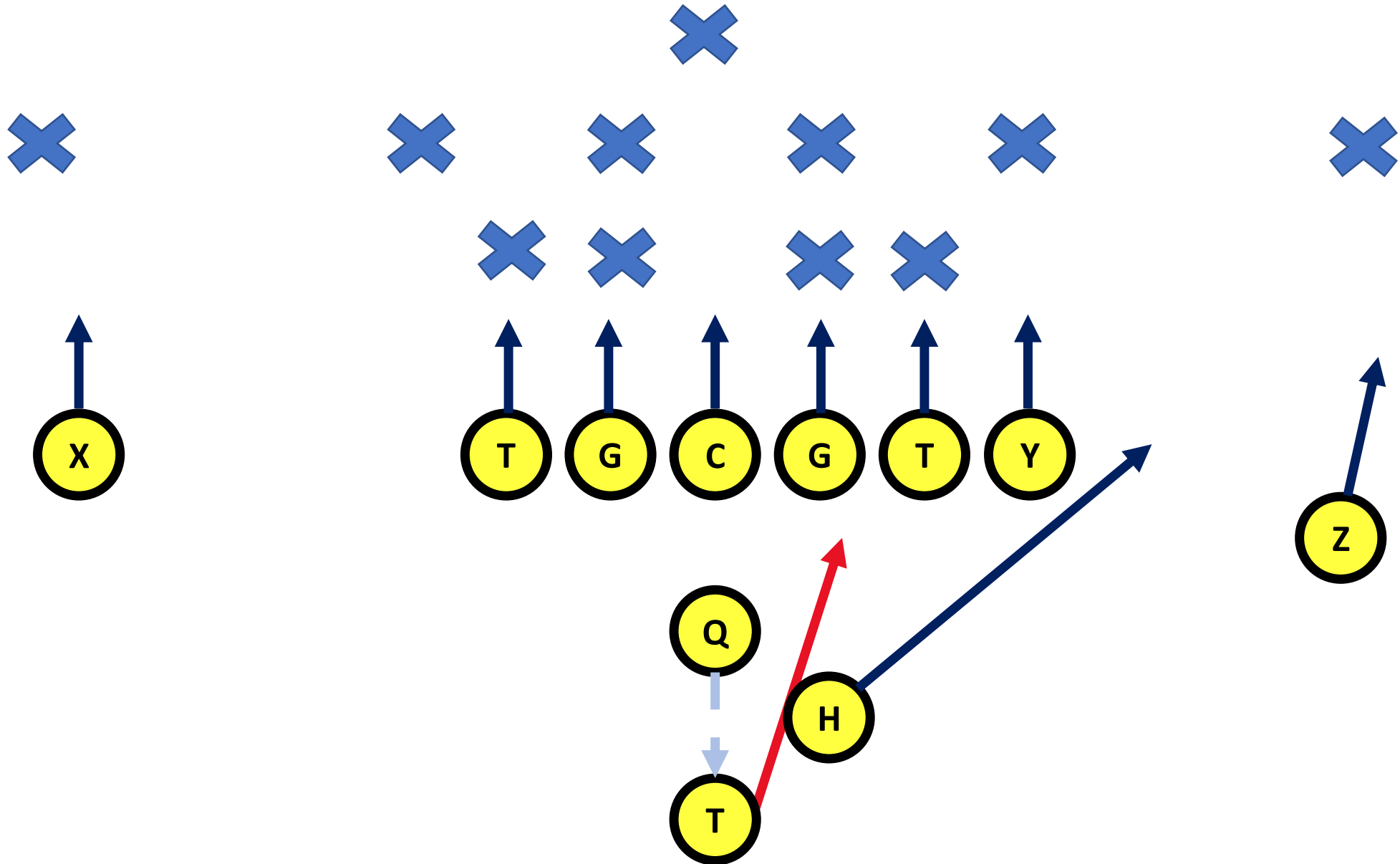



PASSING PLAYS

Pistol Offset I-Formation

I-Right 24 Scissors

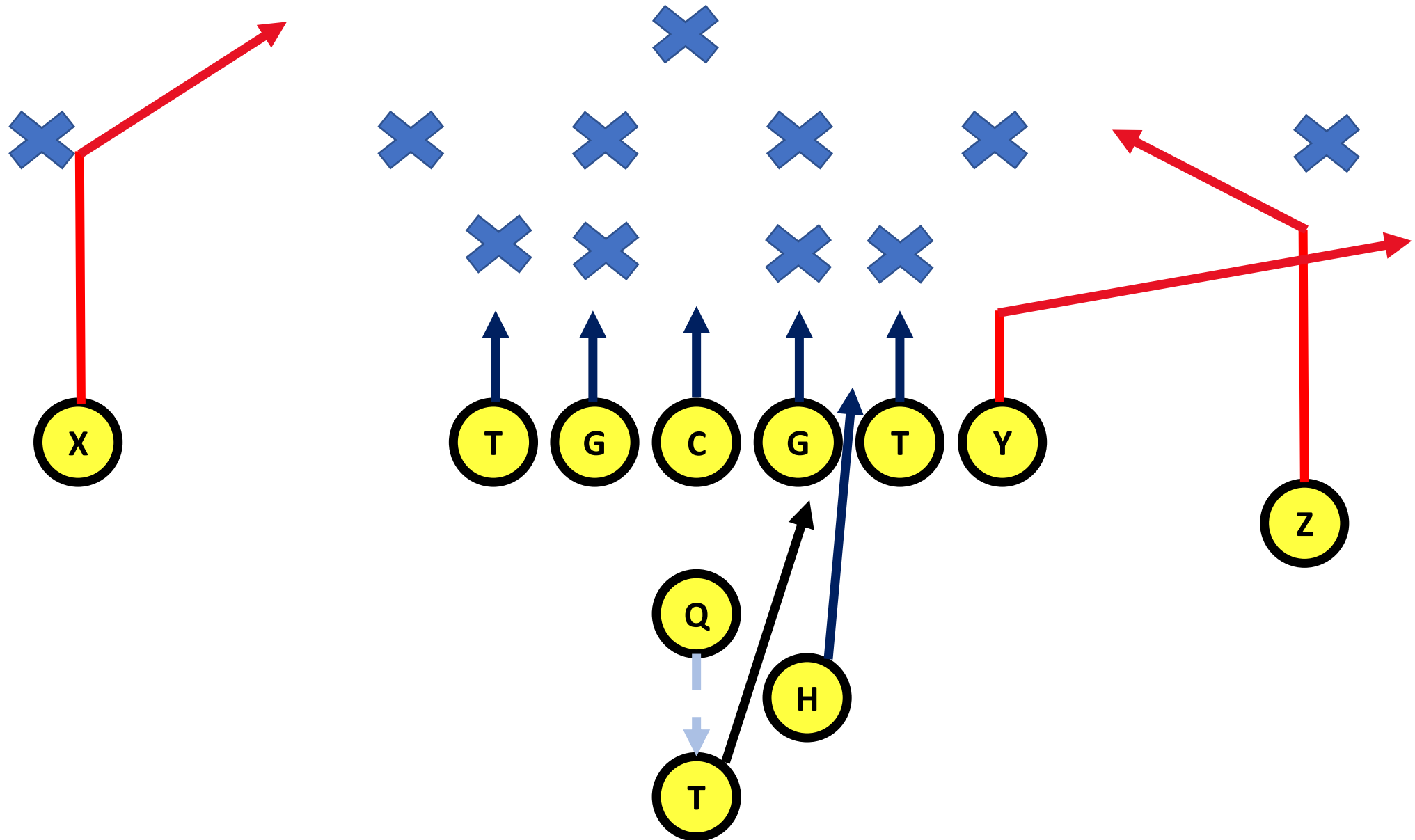

I-Right 24 Smash

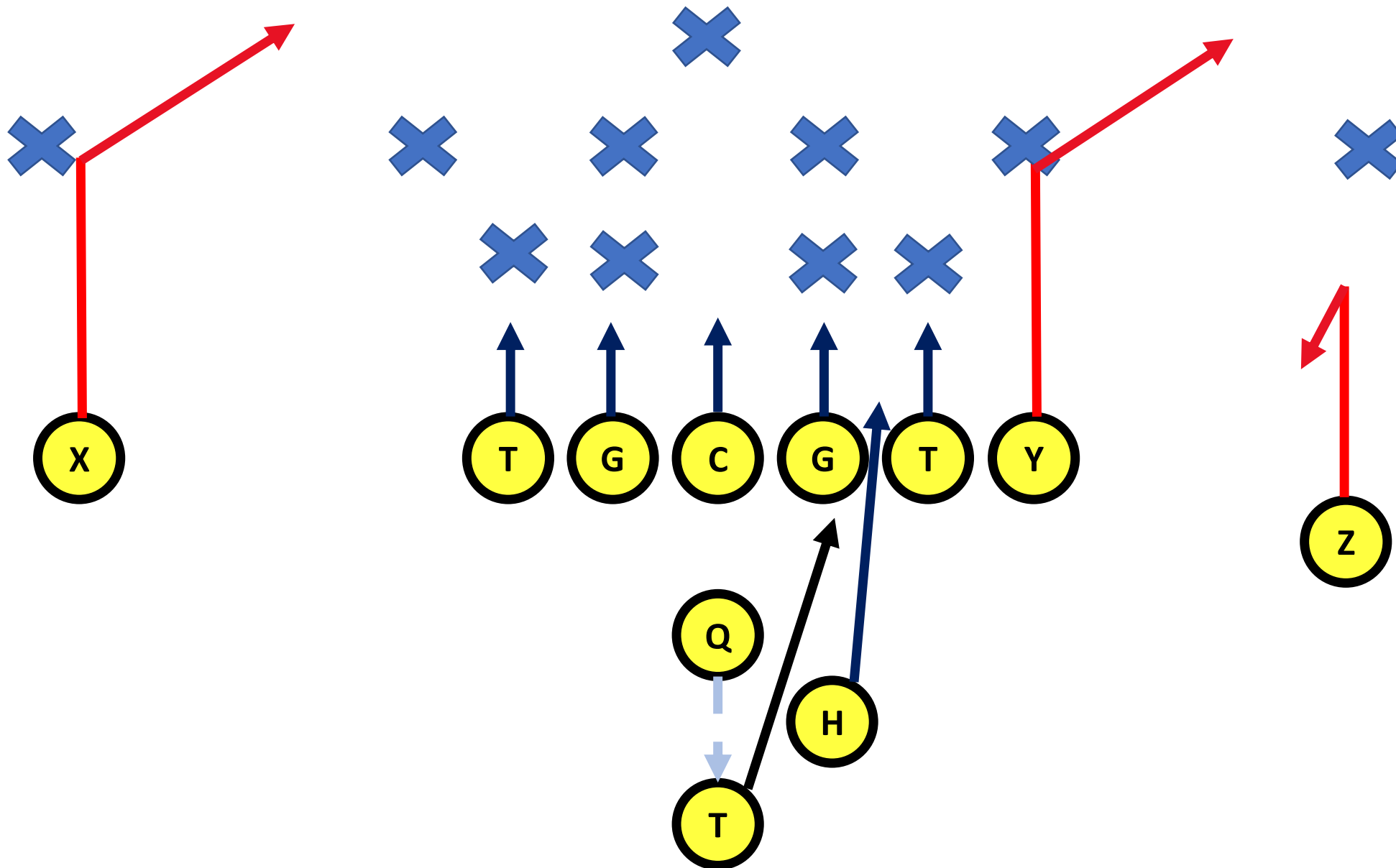

I-Right 24 X Rub

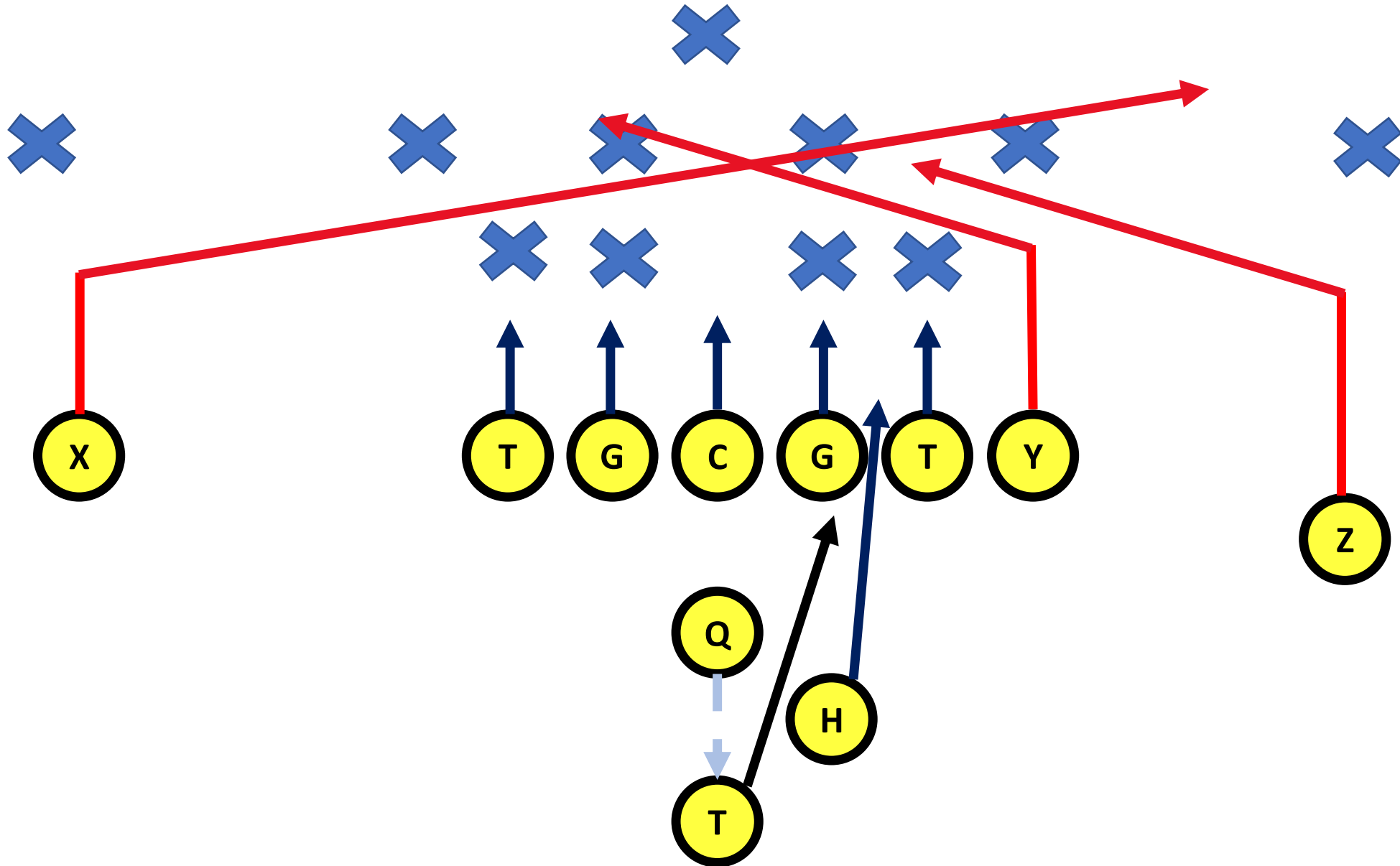

I-Right 24 XZ Post Corner

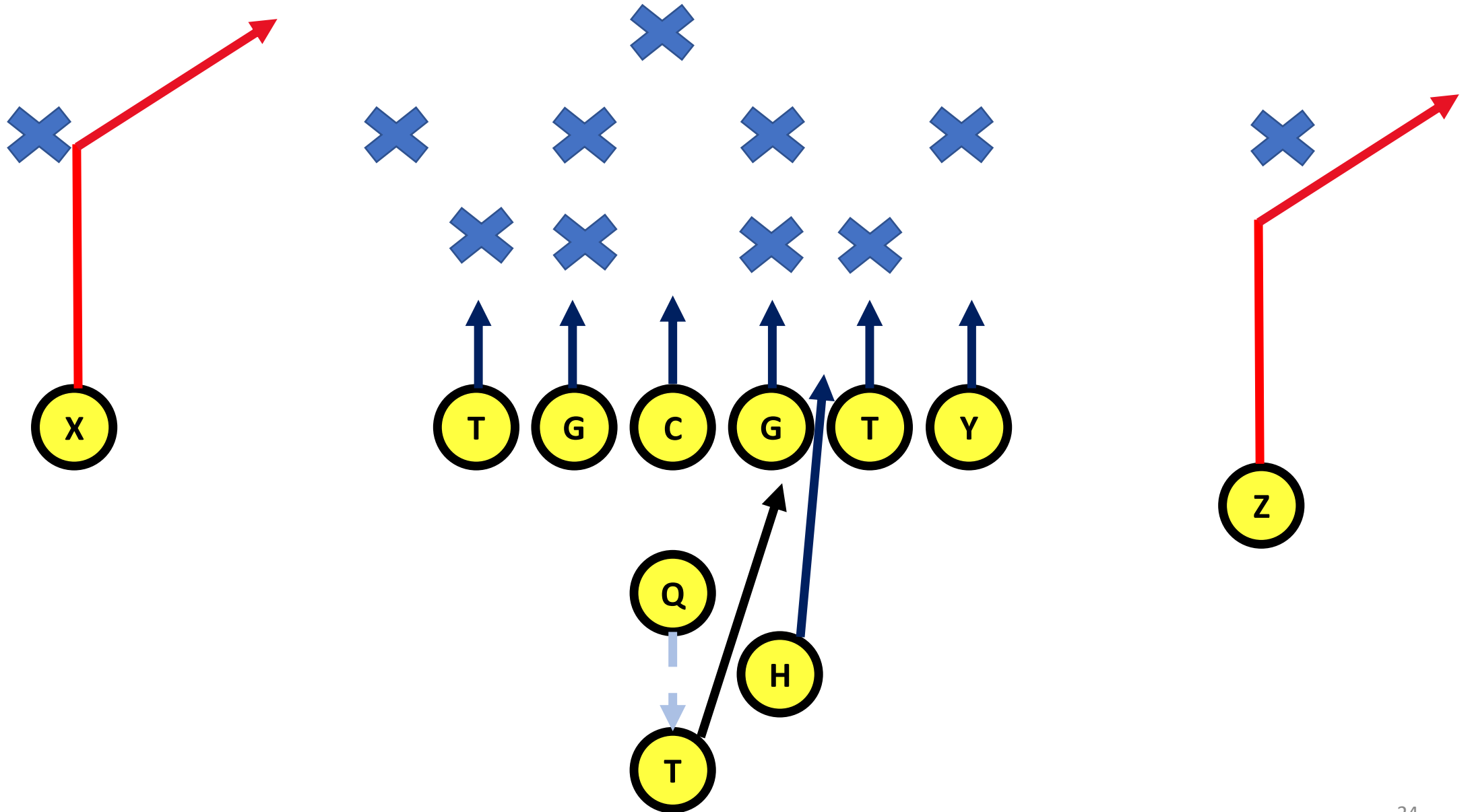

I-Right Speed Option Pass Y Rub

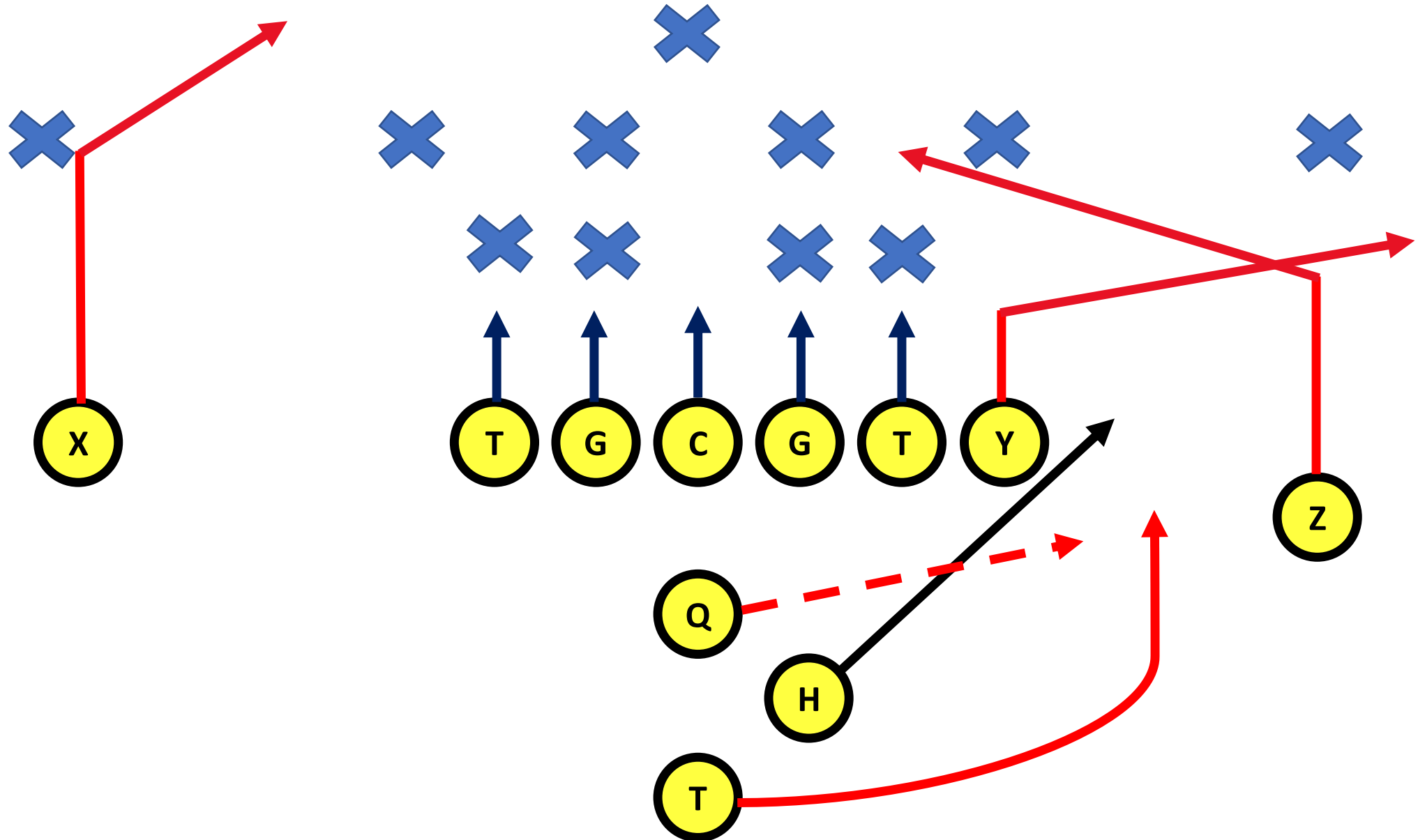



DEFENSIVE PLAYS

“4-4” Defense

5th/6th Grade Position Designations

- (S) Safety – Positioned behind rest of the defense in the secondary.
- (CB) Cornerbacks – In defensive secondary lined up across from opposing team's wide receivers.
- (OLB) Outside Linebackers – Players in the defensive backfield that line up on the outside hip of the Defensive Ends.
- (MLB) Middle Linebackers – Players in the defensive backfield that line up directly behind the Defensive Tackles.

5th/6th Grade Position Designations

- (DT) Defensive Tackles – Positioned on the interior of the defensive line across from the opposing team's offensive guards.
- (DE) Defensive Ends – Positioned on the exterior of the defensive line across from the opposing team's offensive tackles.

"4-4" Defense Formation

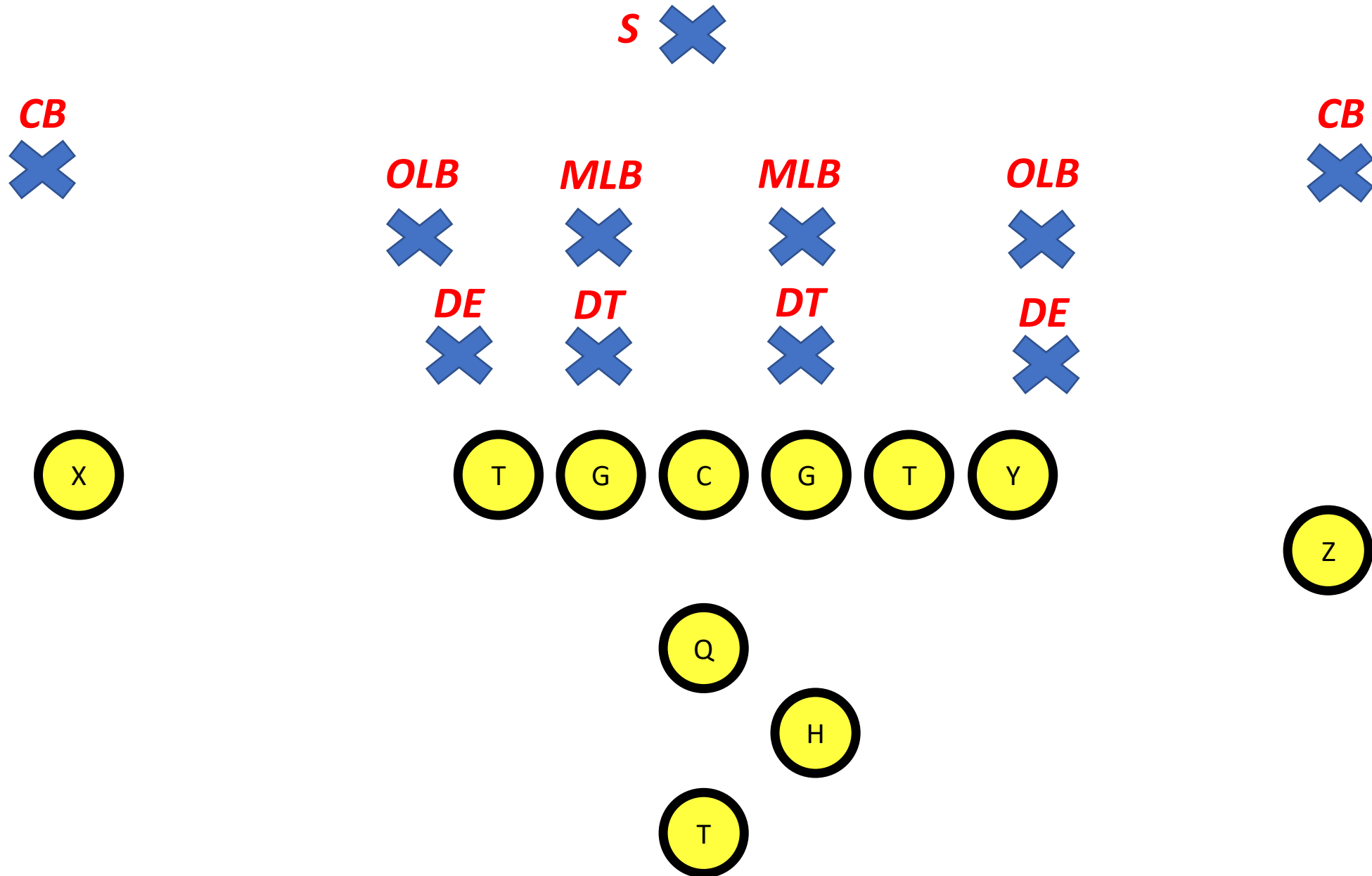

Defense Gap Responsibility

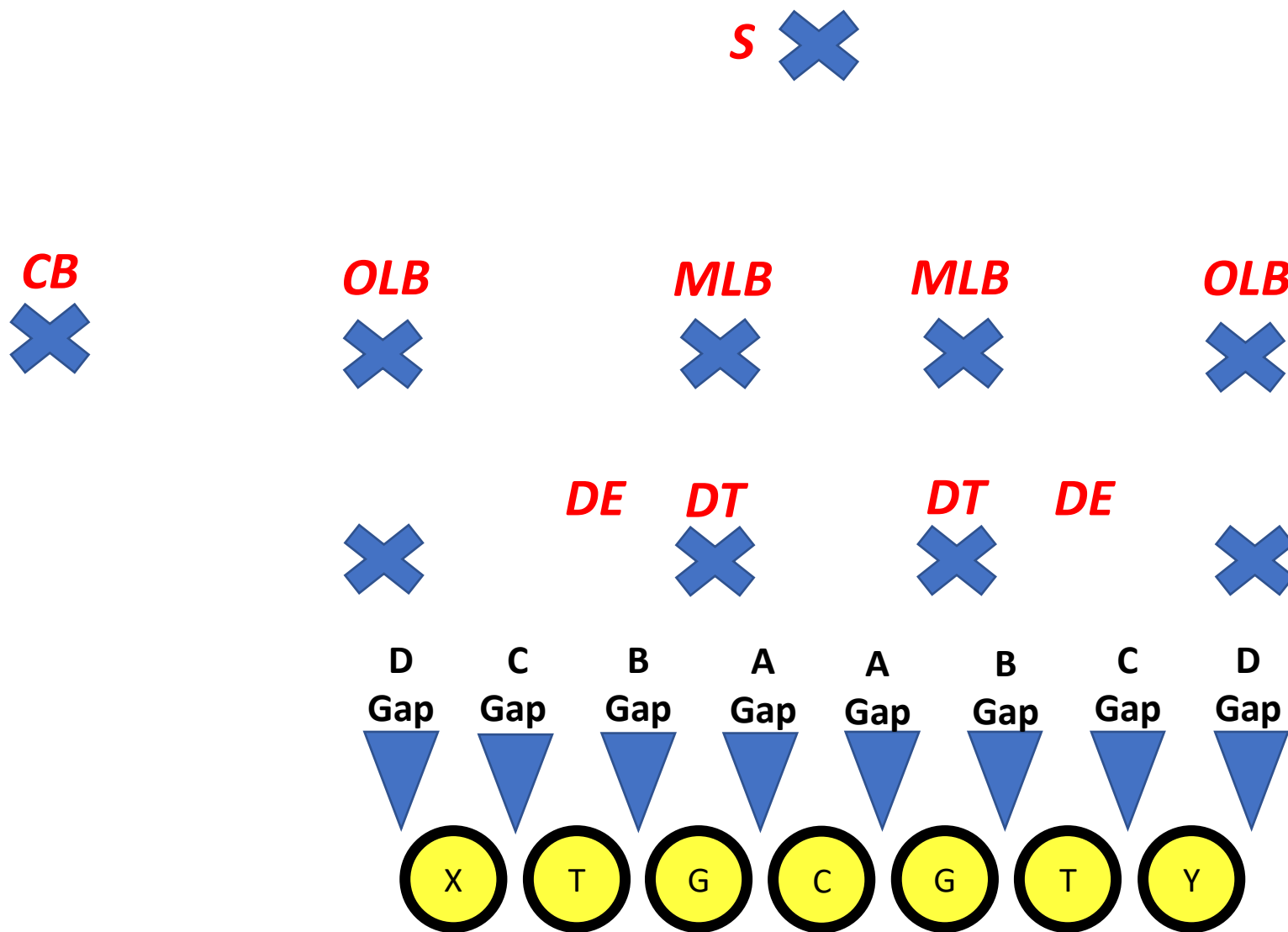

A Gap → Hole between Center & Guard
 B Gap → Hole between Guard & Tackle
 C Gap → Hole between Tackle & Receiver
 D Gap → Hole between Receiver & sideline

- DT has A & B Gap responsibility
- DE has B & C Gap responsibility
- OLB has C & D Gap responsibility
- MLB reads play and attacks A, B or C Gap
- CB has D Gap responsibility